

Mistral pendant lamp

Information

Product code: MT.09.01
 Designer: Sander van der Haar
 Year of design: 2007
 Material: Polyethylene and aluminium
 Included: 2x 5W energy saving bulbs and ceiling cap
 Optional: Custom colours

Colours

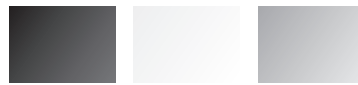

Black White Brushed Silver

Dimensions (Length x Width x Height)

Product: Ø 33 x 45 cm / Ø 13 x 17.7 inch

Package: 47 x 47 x 60 cm / 18.5 x 18.5 x 23.6 inch

Weights

Product: 2,5 kg

Package: 4,0 kg

Marks

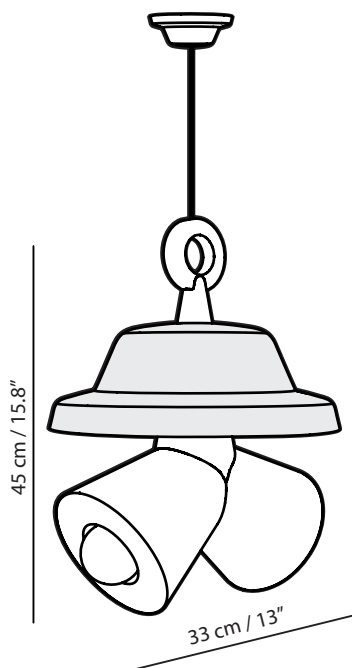
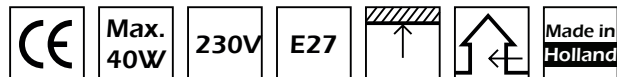

*Specifications are subject to change without prior notice.
 Colours on screen/print may not be representative.